

# COMFORT DYNAMICS LLC

## RESIDENTIAL CONTRACTS

### Terms and Conditions

1-09

- Heating System Repair – Furnaces, Heat Pumps and Boilers
- Water Heater Repair – Natural gas and electric
- Central Air Conditioner Repair
- Internal Gas Line Repair
- Heating Maintenance
- Air Conditioning Maintenance
- Water Heater Maintenance

## TABLE OF CONTENTS

GENERAL TERMS OF CONTRACTS	PAGES	2-4
GENERAL EXCLUSIONS	PAGE	4
WARRANTIES	PAGE	6
TERMINATION	PAGE	6
HEATING	PAGES	7-9
WATER HEATERS	PAGES	10-12
AIR CONDITIONERS/HEAT PUMPS	PAGES	13-14
INTERNAL GAS LINE REPAIR	PAGES	15
ANNUAL MAINTENANCES	PAGES	16

### WELCOME!

Welcome to the Comfort Dynamics LLC residential appliance protection program. By purchasing one of our repair contracts, you are protected from unexpected and costly appliance repairs – saving you both time and money.

You will find that our repair contracts cover the most frequently replaced parts on all major brands. Plus, all repairs are handled exclusively by our certified service technicians, or authorized certified sub-contractors.

This booklet is your official agreement with **Comfort Dynamics LLC** and provides a detailed description of the terms and conditions of our repair contracts. To get the most from your contracts, we recommend that you become familiar with this information and retain this booklet for future reference.

## HOW YOUR RESIDENTIAL CONTRACTS WORK

- The term for Comfort Dynamics LLC repair contracts is one full year.
- There are two distinct types of contracts: repair contracts and maintenance contracts.
- Repair contracts include labor and replacement of certain parts on included equipment when they become inoperable as a result of normal wear and tear. Comfort Dynamics LLC will respond as needed. Contracts do not cover unit replacement.
- A trip charge applies to each repair call and annual maintenances are not included with these contracts:
  - Heating Repair Contract                      – Air Conditioning/Heat Pumps Repair Contract
  - Water Heating Repair Contract              – Internal Gas Line Repair Contract

Your trip charge is determined by the age of your equipment as follows:

- 1-5 Years - \$35      • 5-10 Years - \$45      • 10-15 Years - \$55      • 15-20 Years - \$65
- 20-25 Years - \$75      • 25-30 Years - \$85

### • PIECES OF EQUIPMENT OVER 30 YEARS OF AGE ARE NOT ELIGIBLE FOR REPAIR CONTRACTS

• Maintenance contracts include one annual maintenance only per contract year and include a multi-step checklist to ensure your equipment is in working order. Maintenance contracts do not include any repair work and trip charges do not apply. These contracts include:

- Heating Maintenance Contracts              – Air Conditioning Maintenance Contracts
- Water Heater Maintenance Contracts

All repairs are handled exclusively by our certified Comfort Dynamics LLC technicians or authorized certified sub-contractors. To schedule an appointment, please call

**(520) 471-5121** or visit our Web site: ***www.myblueac.com***

Comfort Dynamics LLC strives to provide timely service to all our customers and assigns a high priority to contract customers.

## GENERAL TERMS OF CONTRACTS

### SEPARATE CONTRACTS FOR EACH UNIT

If there is more than one natural gas furnace or boiler, electric central air conditioner or water heater of the same type in the residence, a separate residential repair contract must be purchased for each unit you want included. Multiple units receive a discount. If there is more than one of the same appliances and only one contract for that appliance type, the contract will apply to the equipment servicing **the first floor or main living area**.

### EFFECTIVE DATE

Your initial agreement officially takes effect at midnight on the 14th day following your verbal or written commitment with Comfort Dynamics LLC. The contract will end one year from the effective date Comfort Dynamics LLC will notify you in writing of your effective date. Effective date \_\_\_\_-\_\_\_\_-20\_\_\_\_

### CANCELLATIONS

You may cancel your contracts at any time for any reason. To cancel, please notify our customer service department at **(520) 471-5121**. If you cancel within the first 30 days of contract and you have not had a service call, you'll receive a full refund. If you have had a service call and subsequent repairs you will be billed for those the service call and repairs at our standard contracting rates. If you cancel after 30 days, **no refunds will be given**.

### CHANGE OF ADDRESS

Contract is not transferable to another address. However, if a contract was paid in full for equipment that remains in operation at the premises, the unexpired term of contract will be applied to the new owner/occupant of the premises at no additional charge. If a contract has not been paid in full, you will be billed for the remaining payments. If you move, call our customer service department at **(520) 471-5121** to cover the appliances in your new home.

### RENEWAL

For your convenience and to ensure that your home is continuously covered, contracts will renew automatically at the end of each 1-year period. Comfort Dynamics LLC reserves the right to change the terms and conditions at any time and to change the contract price upon contract renewal.

### CHOICE OF PAYMENT OPTIONS

If you are a residential customer of Comfort Dynamics LLC, you may pay for contracts in full or make equal payments over a 6- or 12-month period. If you choose to pay on a monthly basis, the charge will appear on your regular monthly statement of credit card of your choosing at initiation of contract. Contract term is for a full 12-month period. If you choose the monthly payment option and decide to cancel before the end of the term, you will be billed for the remaining payments. Non-residential customers and owners who do not occupy the covered residence (landlords) are not eligible for the monthly payment option. Payment in full must be provided prior to beginning contract term.

### SENIOR RATES

Customers over age 62 are eligible for a 10 percent discount. Proof of age may be required. This discount does not apply to landlords or nonresidential applications.

## AGREEMENT CHANGES

Comfort Dynamics LLC RESERVES THE RIGHT TO MAKE CHANGES TO THE TERMS OF THIS AGREEMENT AT ANY TIME WITHOUT PRIOR NOTICE TO PURCHASER.

## MISSED PAYMENTS

If payments are missed or late, Comfort Dynamics LLC may demand immediate payment of the entire amount owed or immediate payment of costs (labor and parts) for all services provided, less any payments made to Comfort Dynamics LLC. Service will not be provided if a customer's account is not in good standing.

## ELIGIBILITY REQUIREMENTS OF ALL EQUIPMENT

- All included equipment must be sanctioned by the American Gas Association, the Underwriters Laboratories or similar natural gas industry trade organizations; installed in accordance with local, state and federal laws; and satisfy both the manufacturer's and Comfort Dynamics LLC' requirements for safe and proper installation.
- Before accepting any equipment for contracts, Comfort Dynamics LLC reserves the right to make an on-site inspection of the equipment.
- To be eligible for contracts, equipment must be warranted by the owner to be in good operating condition, duly assembled and capable of functioning on the contract's effective date.
- Comfort Dynamics LLC reserves the right to deny or cancel contract for certain equipment due to the non-availability of parts, inaccessibility, the condition of the equipment or worksite, or the age of the equipment.

## CONDITIONS OF CONTRACT

- Comfort Dynamics LLC strives to render prompt, efficient and courteous service. Our response time shall be determined by scheduling priorities that consider public safety, health and welfare of customers and employees, existing workloads, the nature of the service call and weather conditions.
- Work must be performed by Comfort Dynamics LLC technicians or authorized certified sub-contractors arranged by Comfort Dynamics LLC. You will not receive credit or reimbursement for work performed, or parts installed, by other service providers under any circumstances.
- All parts under warranty replaced by an Comfort Dynamics LLC technician become the property of Comfort Dynamics LLC without any allowance or rebate at the discretion of Comfort Dynamics LLC. If Comfort Dynamics LLC chooses not to take possession of the parts, it becomes the customer's responsibility to dispose of them properly.
- Comfort Dynamics LLC may use generic parts for replacement when appropriate and necessary.
- Customers must supply safe and ready access to all equipment under contract, including but not limited to OSHA-approved ladders, adequate attic flooring and proper lighting and entry. Comfort Dynamics LLC is not responsible for damage to attic ladders as a result of normal use. For safety reasons, your appliance will not be serviced if it is surrounded by standing water or it is located outside and weather conditions make service unsafe.
- If in the process of repairing an included part, non-included parts are needed to complete the repair, the customer will be charged for the cost of the non-included parts at our standard labor rate.
- If a part which is included under the heat repair contract is replaced while in use as part of an electric central air conditioning system and the customer does not have an Air Conditioning Repair Contract with Comfort Dynamics LLC, the part will be replaced at no charge providing that the customer agrees to pay the labor rate for the air conditioning service call.

## GENERAL EXCLUSIONS

The following items are excluded from contract:

### • Unit Replacements

- Appearance and trim parts, and upgraded components, such as humidifiers and electronic air filters
- Appliance shut-off valves, piping, flex connectors and fittings external to unit (unless Internal Gas Line Repair Contract is in effect)
- Cleaning soot out of, and off of, appliances and flues
- Damage caused by misuse, abuse, vandalism, negligence, fire, freezing, power or water supply outages, flooding, faulty design, improper installation, leaks from piping, humidifiers, lightning, power surges, acts of God and other conditions beyond Comfort Dynamics LLC' control
- Finish defects, rusting, corrosion, chipped porcelain or porcelain flaws, exterior housing or component failure resulting from rust or corrosion on any appliance or piece of equipment
- Materials and labor for any service that is additional to that specified in the repair contract, such as sheet metal work, electrical house wiring, moving or relocating equipment
- Mold cleanup or remediation
- Pre-existing conditions, which include anything that was wrong with your appliance at the time you signed up for the repair contract
- Preventive maintenance and general maintenance (unless equipment is covered by an maintenance contract)
- PIECES OF EQUIPMENT OVER 30 YEARS OF AGE ARE NOT ELIGIBLE FOR REPAIR CONTRACTS
- Seasonal startups (extra charges apply)

### ADDITIONAL CHARGES

- Replacement of standard batteries is not included, but may be provided for an additional charge.
- Parts not included in this contract may be ordered and installed by Comfort Dynamics LLC, when available, for an additional charge at our standard repair rates.
- If the water heater manufacturer recommends replacement of unit after Flammable Vapor Ignition Resistance (FVIR) system fails, the water heater will be deemed not repairable.

## WARRANTIES AND LIMITATIONS ON DAMAGES

COMFORT DYNAMICS LLC WARRANTS THAT, SUBJECT TO THE TERMS AND CONDITIONS STATED HEREIN, COMFORT DYNAMICS LLC WILL REPAIR OR REPLACE THE APPLIANCE PARTS, OR EQUIPMENT COMPONENT PARTS INCLUDED UNDER THE REPAIR CONTRACT, THAT BECOME INOPERABLE AS A RESULT OF NORMAL WEAR AND TEAR.

COMFORT DYNAMICS LLC MAKES NO OTHER EXPRESS OR IMPLIED WARRANTIES OR GUARANTEES OF ANY KIND.

ANY IMPLIED WARRANTIES OR GUARANTEES ARE EXPRESSLY DISCLAIMED. UNDER NO CIRCUMSTANCES SHALL COMFORT DYNAMICS LLC BE LIABLE FOR ANY LOSSES OR DAMAGES OF ANY KIND RESULTING FROM THE FAILURE OR INOPERABILITY OF EQUIPMENT OR SYSTEMS IN EXCESS OF THE PAYMENT RECEIVED BY COMFORT DYNAMICS LLC UNDER THIS AGREEMENT. COMFORT DYNAMICS LLC ALSO SHALL NOT BE LIABLE FOR ANY DAMAGES OR HARM TO PERSONS OR PROPERTY CAUSED BY DELAYS, FAILURE TO SERVICE, MALFUNCTIONING OF THE EQUIPMENT, UNAVAILABILITY OF PARTS, LABOR DIFFICULTIES, ACTS OF NATURE OR OTHER CONDITIONS BEYOND ITS CONTROL.

## TERMINATION

Comfort Dynamics LLC may terminate your repair contracts with no refund in the event any one of the following occurs:

- Parts are no longer available from the original manufacturer, and there are no reasonably available alternate or interchangeable parts
- Removal of a defective part or the installation of a replacement part results in damage to the appliance
- Removal of a piece of equipment results in a safety hazard or an unsafe condition
- Equipment is not used for its designed purpose
- Failure by owner to properly maintain equipment or to replace any parts necessary to maintain the equipment in good condition, including cleaning or changing filters
- Repair costs would be greater than the original value of the equipment

Comfort Dynamics LLC reserves the right to terminate repair contracts for the failure of the owner to comply with provisions of this repair contract.

# NATURAL GAS HEATING SYSTEMS

## Furnace/Boiler

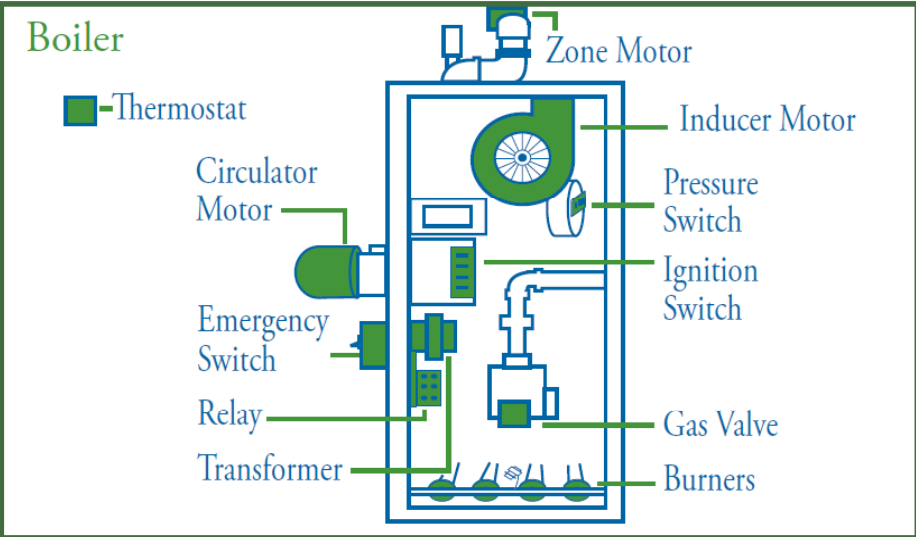
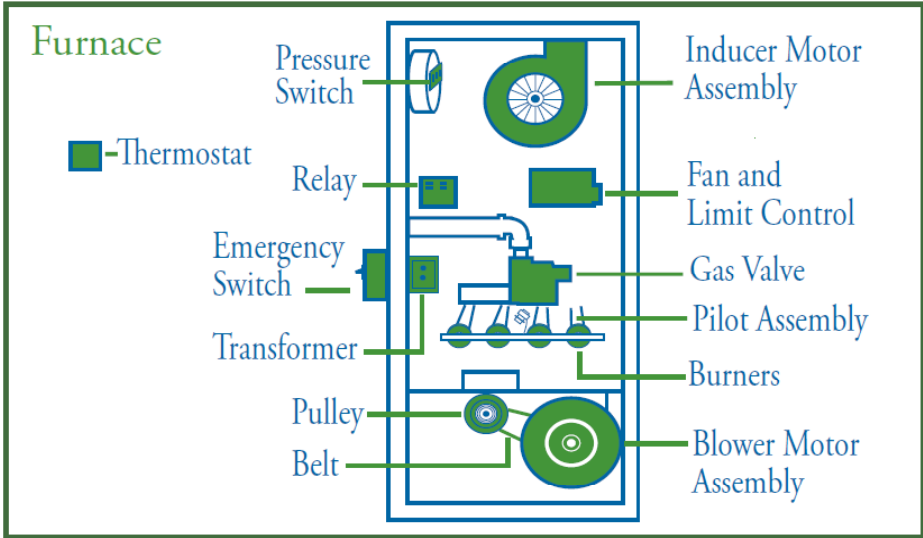

## BOILER/FURNACE PARTS INCLUDED:

- Aqua-stat (dry well)
- Belt and pulley
- Blower motor (PSC Type)/blower wheel (not included June 1 - August 31)\*
- Burners (atmospheric)
- Circulator motor/coupler (only if no water work is involved)\*\*
- Circuit board/ignition control
- Condensate pump on a condensing furnace
- Emergency switch (mounted on unit)
- Fan and/or limit control
- Gas valve
- Ignition system
- Inducer motor and assembly (original part only, excludes sidewall venting kits)\*\*
- Internal wiring
- Low water cutoffs (steam boilers only)
- Packaged, wall-mounted, self-contained combination natural gas heating/air conditioning units\*\*\*
- Pilot assembly/igniter
- Pressure relief valve (steam boilers only)
- Pressure switch
- Relay
- Thermocouple
- Thermopile
- Thermostat\*\*\*\*
- Thermostat back-plate
- Transformer
- Vent damper (original equipment only)
- Zone valve head (only if no water work is involved)\*\*

\* If a replacement is unavailable, and if feasible, the motor will be rebuilt.

\*\* Comfort Dynamics LLC can replace parts not included at standard repair rates.

\*\*\* Packaged units must have both a heating and air conditioning repair contract to be included. Other charges may apply.

\*\*\*\* Truck stock and non-mercury only. Customers who wish to replace faulty thermostat with an automatic setback thermostat may do so at an additional fee.

## BOILER/FURNACE EXCLUSIONS:

- Variable Speed blower motor and/or control modules (unless Variable Speed Blower Motor Repair Contract is purchased)
- Accessory components, such as humidifiers, electronic air filters and zone dampers
- Annual maintenances are not included and must be purchased separately
- Any batteries, whether standard or hardwired
- Anything in the water system
- Cleaning and replacing air filters
- Cleaning boiler water, draining expansion tanks, cleaning sight glass, bleeding air from radiators and hot water heating systems
- Flues, piping and heat exchangers
- Heat transfer fluid
- Natural gas house-heating units rated at inputs of 500,000 British thermal units (Btu's) or more
- Natural gas house-heating units serving more than a 2-family residence
- Tjerlund, Flair, other sidewall venting kits, motors, assemblies, circuit breakers and external wiring
- Does not include replacement of unit

# HOT WATER HEATERS

## *Residential Natural Gas/Electric Water Heater*

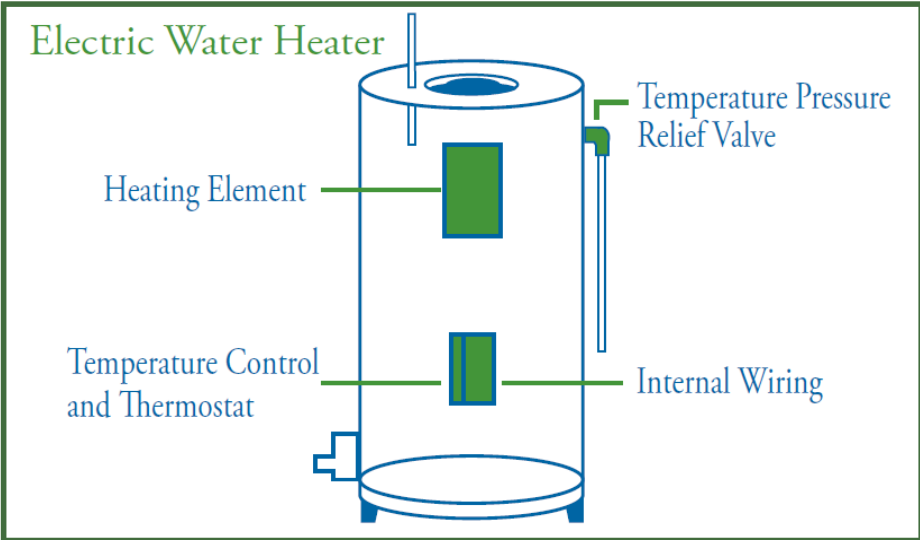
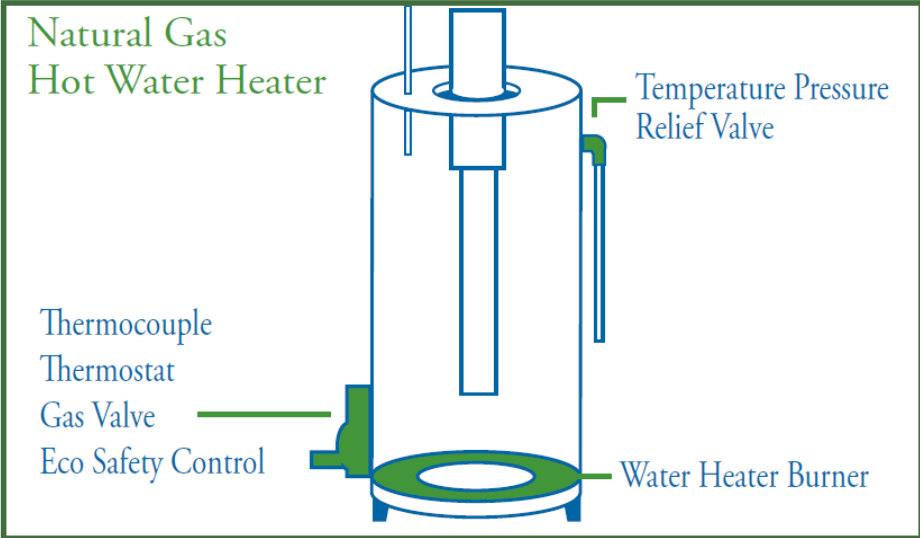

**WATER HEATER PARTS INCLUDED:**

- Access door gasket
- Burner (atmospheric)
- E.C.O. safety control
- Heating element
- Internal wiring
- Manufacturer installed power vents
- Piezo igniter
- Pilot and assembly
- Switching relay
- Temperature and pressure relief
- Temperature control / thermostat
- Thermocouple
- Transformer

**WATER HEATER EXCLUSIONS:**

- After-market power vents
- Anodes
- Circulator pump
- Cleaning and replacing air filters
- Dip tubes
- Drain valves and shut-off valves
- Electric water heating units rated 240 volts or above
- Housing piping and shut-off valves
- Natural gas water heating units rated at 80,000 Btu's or more
- Units over 75 gallons
- Vapor safety systems
- Vent pipe
- Water heater tank failure or leakage
- Water heating units serving more than a 2-family residence
- Wiring and circuit breaker to electric water heater
- Does not include replacement of unit

## Residential Tankless Water Heater

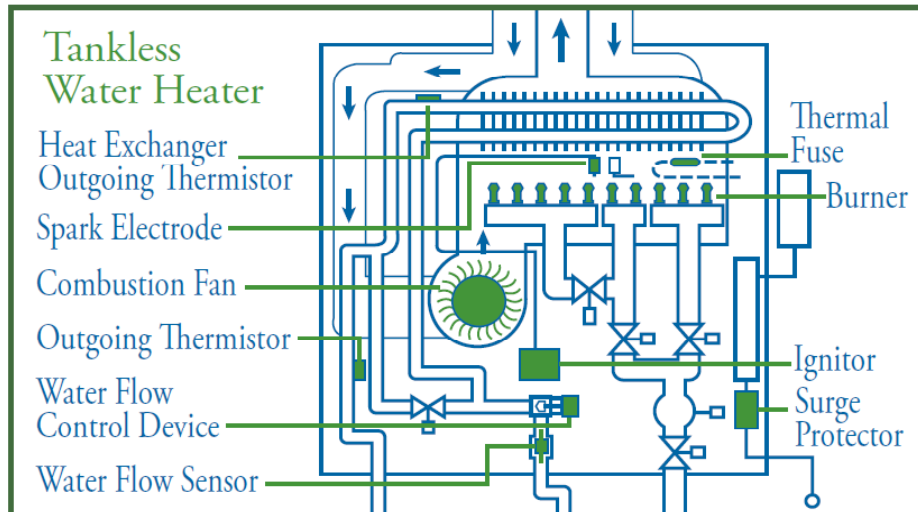

### TANKLESS WATER HEATER PARTS INCLUDED:

- Burner
- Circuit board (PCB)
- Combustion fan
- Igniter
- Overheat switch
- Spark electrode
- Surge protector
- Thermal fuse
- Thermistors
- Water filter and drain
- Water flow control device (exterior models)
- Water flow sensor

### TANKLESS WATER HEATER EXCLUSIONS:

- Electric water heating units rated 240 volts or above
- Heat exchanger
- Mixing valve
- Water heating units rated at 200,000 Btu's or more
- Vent pipe
- Wiring to electric water heater
- Natural gas water heating units serving more than a 2-family residence
- Does not include replacement of unit

### Water Heater Attached to Boiler\*

#### ATTACHED WATER HEATER PARTS INCLUDED:

- Circulator motor, if separate from boiler (only if no water work is involved)
- Zone valve motor or head
- Relay
- Relief valve
- Thermostat

#### ATTACHED WATER HEATER EXCLUSIONS:

- Flow valves
- Gaskets
- Heat exchanger and coil
- Does not include replacement of unit

\* Must have separate Water Heater Repair Contract.

## CENTRAL AIR CONDITIONER/ HEAT PUMPS

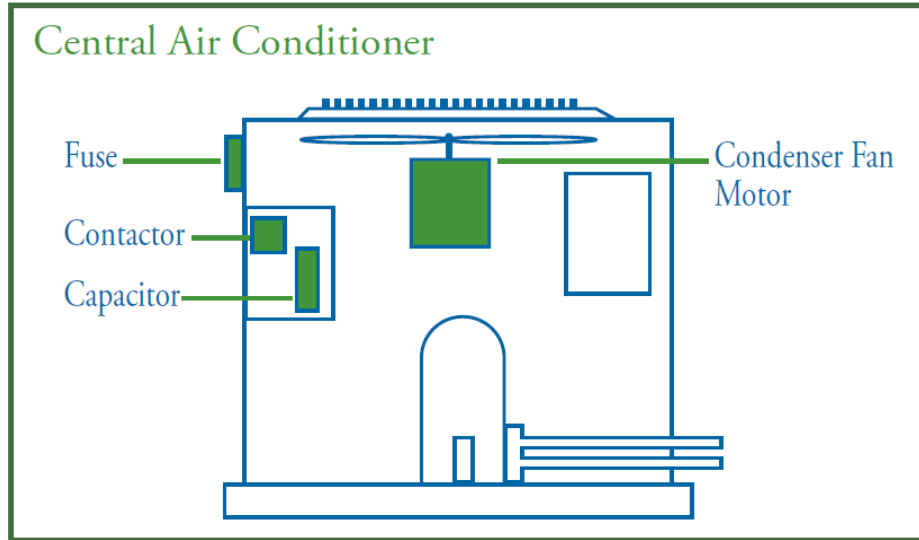

### CENTRAL AIR CONDITIONER/HEAT PUMPS PARTS INCLUDED:

- Belt and pulley
- Blower motor (June 1 - August 31 only)
- Transformers
- Condenser fan motor (PSC Type)/blade
- Contactor
- Time delay controls
- Clean and repair condensate line (only if line is visible and accessible)
- Condensate pump
- Defrost cycle relay (heat pump)
- External crankcase heater
- Thermostat\*\*
- Fuse (cartridge type)
- Low ambient temperature control
- Motor speed control
- Refrigerant\*
- Relays
- Run capacitor
- Start capacitor
- Low-voltage wiring (only if wiring is exposed and accessible)

\* If unit needs refrigerant added more than once, subsequent injecting will be completed only after a thorough leak investigation at Comfort Dynamics LLC standard repair rates.

\*\* Truck stock and non-mercury only. Customers, who wish to replace a standard thermostat with an automatic setback thermostat, may do so at an additional fee.

## CENTRAL AIR CONDITIONER/HEAT PUMP EXCLUSIONS:

- Annual maintenances are not included and must be purchased separately
- Any repairs that require accessing the refrigerant system, including leak investigation, leak repairs, internal blockages and all internal component replacements
- Cleaning evaporator coil (unless Coil Repair Contract is purchased; under this agreement coil will only be cleaned once every 5 years of continuous repair contract renewal)
- Compressor (unless Compressor Repair Contract is also purchased Dual Compressor Repair Contract is required if your unit has 2 compressors and you want compressor repair)
- Condenser or evaporator (unless Coil Repair Contract is purchased)
- Disconnect, circuit breaker or electrical wire
- Refrigerant piping (line sets)
- Residential air conditioners/heat pumps above five tons
- Variable speed condenser fan motors (unless Variable Speed Condenser Fan Motor Repair Contract is purchased)
- Does not include replacement of unit

**Note:** Outside temperatures below 65 degrees, excessive attic temperatures and/or inclement weather may prevent the completion of air conditioning repairs until conditions permit.

## INTERNAL GAS LINE

### INTERNAL GAS LINE PARTS COVERED:

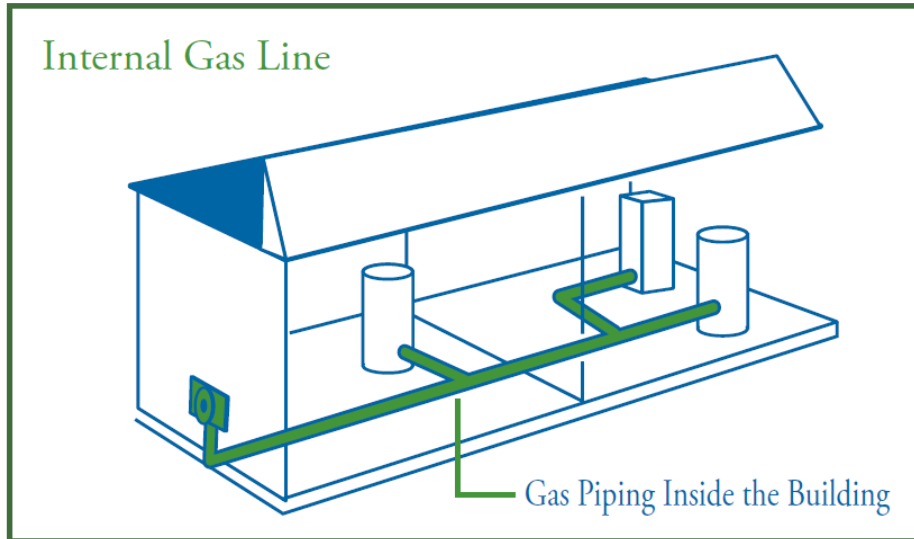

### INTERNAL GAS LINE PARTS INCLUDED:

- Black and/or galvanized piping from 1/2" to 1 1/2" diameter in size
- Includes 1/2" and 3/4" shut-off valves (leaking or inoperable)
- Replacement of flexible connectors on hot water heater and furnace, if completely accessible (replacement only if leaking or as needed)
- Leaks in crawl spaces and attics on exposed pipe, if accessible
- Repairs are limited to \$2,500 maximum per occurrence

### INTERNAL GAS LINE EXCLUSIONS:

- Any piping not up to code
- B valves
- Damage caused by third parties or natural disasters
- Facilities used for commercial purposes
- Natural gas meters
- New construction covered under warranty
- Mobile homes and trailers
- Nothing outside the home is included – including any appliances inside detached garages
- Repairs to yard lights, grills and pool heaters
- Restoration to affected areas
- Unexposed pipe
- Vent-less fireplace valves or piping to a fireplace
- Services such as connecting or disconnecting appliances

## ANNUAL MAINTENANCE

Maintenance contracts are not included with standard Heating and Air Conditioning Repair Contracts and must be purchased separately. It is the customer's responsibility to call Comfort Dynamics LLC to schedule the annual maintenances. Scheduling during peak months of October through December may be restricted due to volume of emergency work.

### HEATING MAINTENANCE

- Check draft hood
- Check for adequate airflow for combustion or ventilation
- Check for proper draft at flue
- Check visible flue pipe
- Check safeties
- Check for proper operation of furnace
- Check thermocouple, replace if necessary
- Check operation of blower and circulation pump
- Check thermostat and controls
- Inspect blower belt
- Light and adjust pilot burners
- Lubricate all moving parts as needed

### AIR CONDITIONING MAINTENANCE

Scheduling of maintenance is dependent on the outside temperature being greater than 65 degrees. Excessive attic temperatures and/or inclement weather may prevent the completion of air conditioning maintenances until conditions permit.

- Check for proper operation of air conditioner
- Check voltage and amperage draw
- Check electrical connections, refrigerant lines and proper system operations
- Check condensate drain
- Check condensate pump
- Check operation of blower
- Inspect blower belt
- Lubricate all moving parts as needed
- Check thermostat and controls
- Check safeties

### WATER HEATER MAINTENANCE

Water heater maintenance is only available in addition to a Heating Maintenance Contract and only performed during a SCHEDULED HEATING MAINTENANCE VISIT.

- Check draft hood
- Check for adequate airflow for combustion or ventilation
- Check for proper draft at flue
- Check visible flue pipe
- Check thermostat and controls
- Check for proper operation of water heater
- Check thermocouple, replace if necessary
- Check operation of blower and circulation pump
- Light and adjust pilot burners
- Flush tank
- Install cap on drain valve if needed
- Check heating elements
- Check voltage and amp draws
- Check safeties